

Portable Evaporative Air Conditioner with PEC — TAC-150

— Here is the innovative way to provide cool and dry air without using compressor and refrigerant

How it works

Located next to the exhaust mounted on a wall or window, the evaporative air conditioner draws warm air from the room. The warm air is drawn through the Psychometric Energy Core (PEC) and split into two streams. One stream flows through the wet channels in the PEC to enhance evaporation of water sucked in the PEC and thus to cool the other air stream in the dry channels within PEC. The cooled air stream will then be circulated into the room. The warm air stream mixed with vapour will be discharged outside the room. After several circulations, the room temperature will be reduced to certain temperature and the circulation fan can be stopped until the room temperature rises again.

In the system, no compressor is used. The energy consumption of the fan is very low. In the device, only water is the cooling media and no refrigerant is used, therefore, it is environmental friendly. Since no vapour is mixed with the cooled air, the RH of the cooled air is almost same as that of the air drawn into the device. The device should perform much better within dry and hot environment.

They can be easily used in your bedroom, lounge or conservatory

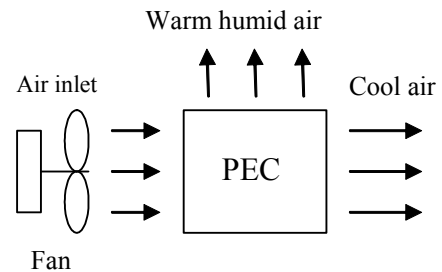
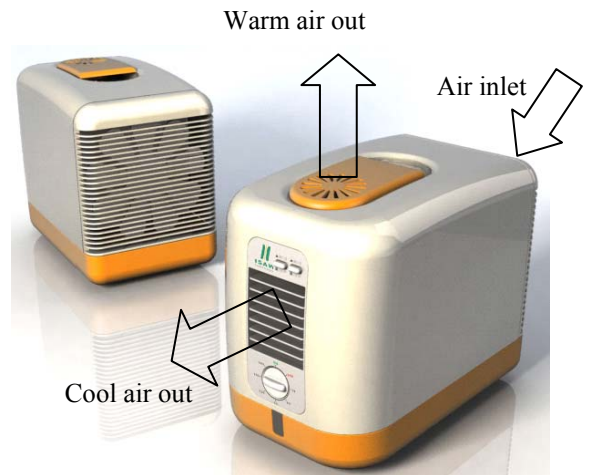

Specifications

Type	TAC-150
Power	220V~240V/50Hz/Single Phase
Max total flow rate	150 m ³ /h (88 CFM)
Max cooling capacity	400 W
Water consumption rate	1.05 litre/hour
Water reservoir	4.3 litre
Max fan power	30W
COP	up to 12W / W
Noise level	30 dBA
Size	450×300×370mm
Weight with no water	5 kg
Design condition	30°C with RH 50%

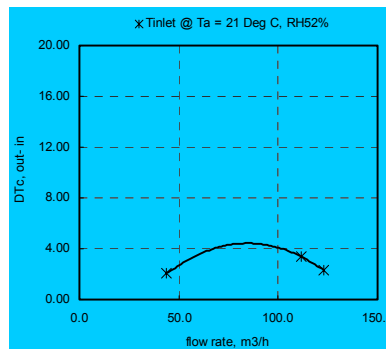

Performance curve at ambient of 21°C and RH 50%

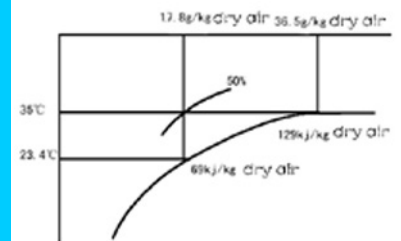

Using Psychrometric Chart to predict air temperature drop and RH



Take Free.
Take the World.

Products Series
MHM3CIBR1FAFC
PECIPEAC1FAFC



Get your room full of Free good air !

From **Sick Building Syndrome** to **Healthy Building Respiration**

SBS

HBR

From **Air Conditioning** to **Fresh Air Flow Conditioning**

AC

FAFC



FREE SCIENCE & TECHNOLOGY DEVELOPMENT CO. LTD

Add: Xiasha Economic Develop Zone, Hangzhou, Zhejiang, China

Tel: 86 571 86934959

Fax: 86 571 86937157

Email: iisaw@163.com

<http://www.isaw.com.cn>

FREE SCIENCE & TECHNOLOGY DEVELOPMENT CO. LTD

Intraduction

Free FAFC Science & technology development Co.Ltd ,is a Sino-US Joint Venture. Its staff consists of well-known Chinese and United States based experts .It is situated at Xiasha economic develop zone, in the city of Hangzhou, Zhejiang province, PRC. Our registered trademark is "IISSAW" .

The major efforts are related to further research and development, production, and sales of " Mico Heat & Mass Cell Cycle Core " [MHM3C] devices and "Psychro-metric energy core" [PEC] devices. Our products include various kinds of MHM3C and PEC, which can be configured into various structures fitting into almost any space; and various products characterized with MHM3C or PEC, such as Building Respirator(BR),and psychrometric energy air cooler (PEAC) and the "Fresh Airflow Conditioner" [FAFC] incorporated with MHM3C or PEC, which could offer totally fresh and purified air to replace stale room air .

Original theory

Micro heat and mass cell cycle theory is the revolutionary breakthrough is heat and mass transfer and represent one of the most important developments in the history of heat and mass transfer science and technology. "Psychrometric energy theory " is an original theory on the energy resetting from the process of the interaction of air with hygroscopic solutions including water and salt solution etc. This theory break through will lead to series innovation in techniques, applications and related products.

An industry problem

Traditional air conditioning is simply treats the energy level of indoor air as this air is, for the most part, constantly recirculated within the building. This leads to increases in air borne pollutants and impurities. Moreover, there are inadequate basic elements such as oxygen, that is abundant in outside fresh air and favourable for human breath and health. The result is the so-called sick building syndrome with attendant increase in human sickness along with worker absenteeism and reduced productivity. While the supply of fresh air is being increased by mandates throughout the world, there is no economical method for its achievement.



An unique solution:FAFC

An elusive goal has been to develop a technology that economically allows full replacement of the indoor air with conditioned fresh air flow. A new concept called " Fresh air flow conditioning" [FAFC] accomplishes this goal by managing the energy level contained in fresh air before it enters the building. It is now the fresh air flow that affects the indoor environment, not alterations to recycled stale building air.

"FAFC" changes the concept of the traditional "AC" ; FTAC means 2 aspects: one is conditioning the Fresh air flow, another is increasing Fresh air flow within the indoor environment.

Innovation technology

The patent pending breakthrough solutions seem overly simple and economical, MHM3Cmembrane when liquid coated, allows heat and moisture to pass from one air stream to another but prevents the air from doing so, the inexpensive and safe liquid refreshes the paper periodically so there is no decay in operating efficiency nor any build-up of impurities.

PEC become wall when one side of wall is wetted with water, one stream of air can absorb heat from the other side, cooled without moisture increase, while a second stream of air becomes humidified and gains a higher enthalpy. The enthalpy diffience between the two air streams is so called psychrometric energy .MHM3C & PEC devices make the FAFC into reality.

Products

MHM3C:basic device for heat and mass transfer between gases.

Building Respirator(BR): to realizes enthalpy recovery between fresh air and exhaust air from buildings; and provides flirrtation, purification and sterilization of any air .

PEC: basic device for producing psychrometric energy resetting in cooling. Psychrometric energy cooler, to realize utilizing psychrometric energy .

Fresh airflow conditioner [FAFC]: combination of any air conditioner with MHM3C devices.

Sale and service

Supply of standard and custom required MHM3C and PEC.

Supply of standard and custom required BR and PEAC

Supply of custom required FAFC

Design of system with MHM3C and PEC and related products.

Gentleman know that fresh should be kept in its proper place-out of doors-and that
God having given us indoors and out-of-doors.
We should not attempt to do any with distinction.

——Macaulay, Rose British poet.

Principle

Fresh air or room air in the room is brought into IISAW PEC via a fan, and the inlet air flow is divided into a cooling stream and a stream to be cooled. Within PEC, the cooling air stream within the wet channels will be pre-cooled by water via evaporation and becomes a cool air flow mixed with vapour. The stream to be cooled and circulated into the desired region will flow within the dry channels. The stream will be cooled close to the dew point by the cooling air stream. The cooled dry air can be supplied into the region near people. The cooling air mixed with vapour and sensible heat will also be discharged from the PEC into other regions or outside the room. Water within PEC will be supplied from the reservoir located at the bottom of the unit, and thus continuous cooling can be realised.

PEAC: BREAKTHROUGH
DEVICE FOR FREE COOLING

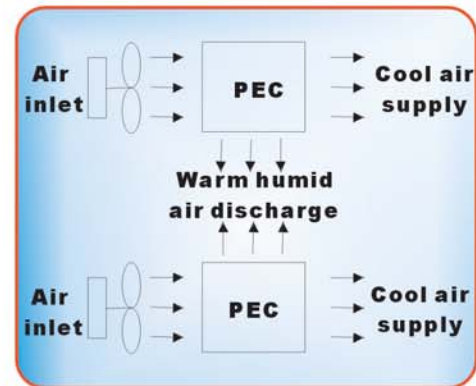

Features

- The unit can provide cool air without increasing humidity and thus can offer comfort cooling effect, when compared with conventional evaporative cooling devices which can not separate cooled air and vapour.
- The fan is the only moving component, therefore the energy consumption is very low. The COP will be 30W/W or higher for maximum cooling capacity at minimum operational cost.
- The unit utilizes psychrometric energy for cooling without any CFC refrigerant. Therefore it is environmental friendly.
- Since there is no moving component except the fan, its operation has a very low noise level.
- There is no compressor within the system, thus the product is long lasting. The water consumption is low, due to the use of PEC.
- The configuration of the product is relatively simple. It is easy to maintain and it is multifunctional.
- Extra functions can be added, subject to user selections.
- It is small, light and easy to move. It can be placed in different regions.
- Due to modular construction easy adaption to larger air quantities.

Application

Residential house and apartment
Office
School
Super market
Hospital
Factory
Any building requiring ventilation



Technique data

PEAC: BREAKTHROUGH
DEVICE FOR FREE COOLING

Task Air Conditioner series

Design conditions: Dry bulb temperature at inlet = 35°C and Wet bulb temperature = 20°C (i.e. equivalent relative humidity = 23%); altitude above the sea level is 100 m; the inlet air is 100% fresh.

CODE	TAC-2000	TAC-3000	TAC-4000	TAC-6000
Flow rate M ³ /h	2000	3000	4000	5000
Cool air temperature °C	22	22	22	22
Cooling capacity (W)	8000	12000	16000	24000
Water consumption (L/H)	13	20	26	40
Fan power (W)	250	360	500	800
Overall size (L×W×Hmm)	730×680×1280	730×1000×1280	780×1360×1280	930×1360×1280
Weight (kg)	80	120	160	200

Portable Air Conditioner series

Code:	TAC-150(A/B)
Power:	220V/1PH/50HZ
Flow rate:	150 m ³ /h
Cooling capacity:	400 W
Water consumption:	1.05 L/h
Reservoir volume:	4.3L
Overall size(Length×Width×Height):	450×300×370mm
Dry weight:	5kg
Type TAC-150A:	DC motor to drive fan
Type TAC-150B:	DC motor to drive fan

Type TAC-150A:DC motor to drive fan

Type TAC-150B:DC motor to with battery for 7.2Ah

Design conditions: Dry bulb temperature at inlet = 30°C and Wet bulb temperature = 22.5 °C; Equivalent relative humidity = 50%



Basic Principle

PEC: BREAKTHROUGH DEVICE FOR PSYCHROMETRIC ENERGY UTILIZATION

There are various kinds of natural energies existing in the air. The psychometric energy is just one kind of natural energies, which is ubiquitous, regenerative and can be easily obtained. The so-called psychometric energy is the energy produced by any unsaturated airstreams transformed by the PEC. Take the air under a standard air pressure with the condition of 35°C, 40% as an example such as A, its enthalpy psychometric energy is 72kJ/kg dry air (129-69), i.e. Air A can be transferred into A1, A2 two states by PEC. A1 is the dew point of A, the conditions are 19.5°C, 14g/kg, enthalpy value 55kJ/kg. A2 is the saturated air of A isothermally with the conditions 35°C, 36.5g/kg, enthalpy value 129kJ/kg. (See Fig1, Fig2). Surely A1, A2 are idea states, A1', A2' are obtainable states.

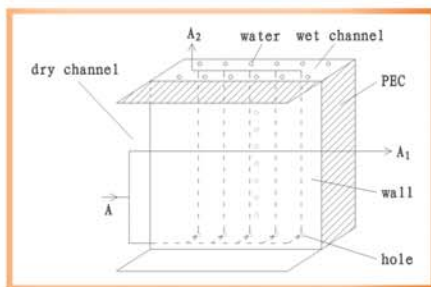

Fig1

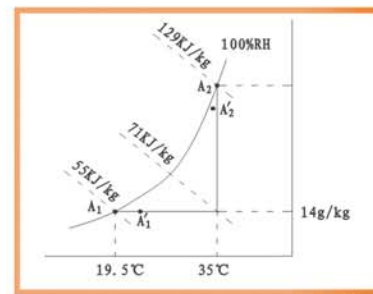

Fig2

Basic Principle

As mentioned above, PEC can change the unsaturated air into two states. One is low-temperature, low-enthalpy and the other is high temperature and high-enthalpy.

Principle scheme on PEC (please see Chart 3)

A1 is the heat exhaust side of the heat transfer wall, and it divides into self-cooling area and is itself one, it sets some apertures in self-cooling area. B1 is the heat absorb side of the heat transfer wall, it distributes material which can be humidified by liquid, and it has the function of capillary action. The channel in the heat exhaust side between two heat transfer walls is the heat exhaust channel, the channel in the heat absorb side between two heat transfer walls is heat absorb channel. The air is sent into the heat exhaust channel in the heat exchange core, the air that enters from self-cooling area is cool air, and the air that enters from itself-cooling area is cooled air. The air that enters into the self-cooling area of heat exhaust channel in the heat exchange core gradually enters into the heat absorb channel through the apertures in the heat transfer wall, due to the liquid evaporation in the heat absorb channel, absorb the heat from heat exhaust channel, and to decrease the air temperature of the heat exhaust channel.

The air of the self-cooling area in the heat exhaust channel is cooled before it enters into the heat absorb channel through the apertures in the heat transfer wall, due to the liquid evaporation, incessant saturation and absorbs the heat of the air in heat exhaust channel, to further lower the air temperature in the heat exhaust channel of the self-cooling area. All air that enters into the heat absorb channel is sent into the itself-cooling area to cooled the air which needs be cool after it enters into self-cooling area, and then exhausted. Due to the temperature gradients, existing needs in the direction of air flowing in the heat absorb channel, cause the air to continually lower its dry bulb temperature, until it cools close to its dew point temperature. Meanwhile, the temperature gradation also exists in the cool air in direction along the heat absorb channel, and its temperature is increase incessantly.

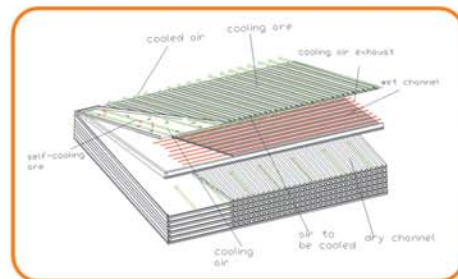

Fig3

Application

- Natural psychometric energy Air conditioner
- Condenser
- cooling tower
- Humidifier
- Fresh Air conditioner

Basic Principle

PEC: BREAKTHROUGH DEVICE FOR PSYCHROMETRIC ENERGY UTILIZATION

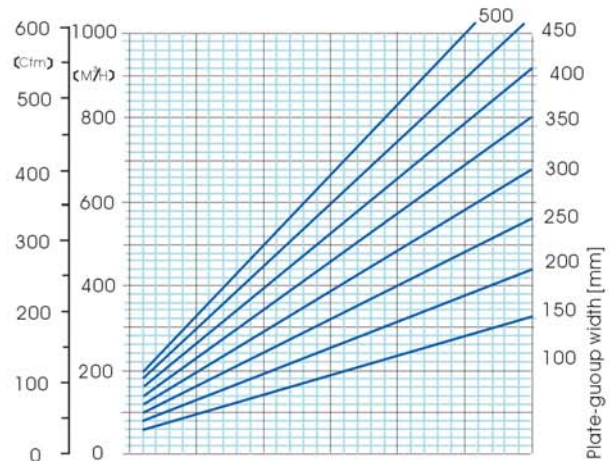
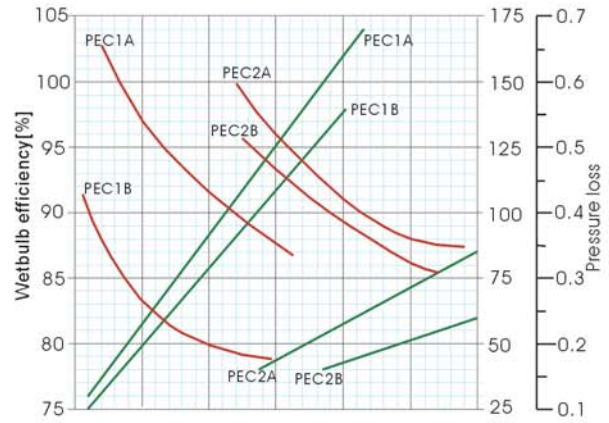
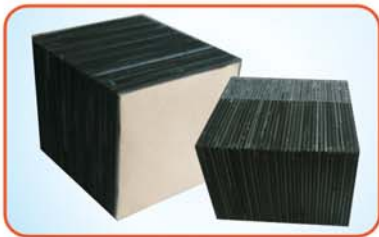
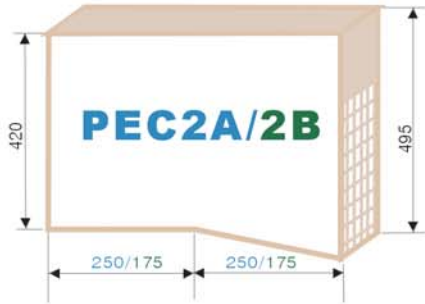

This diagram applies to exhaust air mass flow equal 60% of supply

Installation patterns

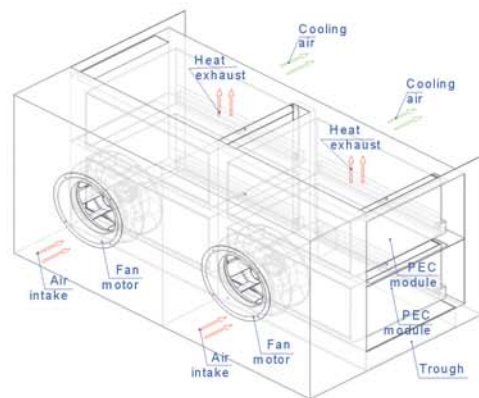
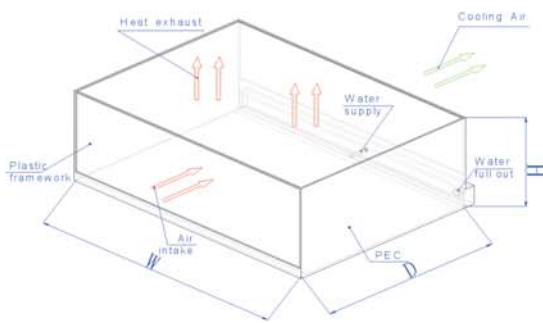

Due to modular construction easy adaption to larger air quantities!